

389 Chiswick High Road
London W4 4AL
Tel: +44 (0) 20 8996 9000
Fax: +44 (0) 20 8996 7400
www.bsigroup.com

Committee Ref: GSE/029

Date: 2018/08/02

Direct details:

Telephone: 020 8996 7147
E-mail: peter.slot@bsigroup.com

Dear Member,

DOCUMENT FOR FINAL VOTE AND APPROVAL TO PUBLISH

DEFAULT UK VOTE: Approval
COMMENTS TO peter.slot@bsigroup.com BEFORE 2018/09/20

Please find attached: FprEN 13203-2 , Gas-fired domestic appliances producing hot water - Part 2:
Assessment of energy consumption

This document is circulated to National Committees for approval to progress to publication.

- If the UK votes yes or abstains, it is BSI's policy to implement this document as a British Standard with no further input from the Committee.
- If the UK votes no, we have to provide a technical justification at this stage and this will form the basis of additional information in the National Foreword of any resulting British Standard implementation.
- Additional texts to the National Foreword or National Annex will require endorsement from your Committee Chairman.

Note 1) Only technical comments accompanying a negative vote can be submitted at this stage and they have to be submitted on the correct [comment template](#). If you have any queries on how to use the template then please do not hesitate to contact your Committee Secretary.

Note 2) We are obliged to implement all European Standards and our policy is to implement as full a package of International Standards as possible.

Note 3) If you do not consider an International Standard suitable as a British Standard please discuss with your Committee Secretary.

Please notify your Committee Secretary if you are aware of any keywords that might assist in classifying or identifying the standard or if the content of this standard:

- i) has any issues related to 3rd party IPR, patent or copyright,
- ii) affects other national standard(s),
- iii) requires additional national guidance or information.

If we do not hear from you by the above date we shall submit a vote of approval to ISO on behalf of the UK committee.

Yours sincerely

Peter Slot
Secretary to GSE/029

August 2018

ICS 91.140.65

Will supersede EN 13203-2:2015

English Version

Gas-fired domestic appliances producing hot water - Part 2: Assessment of energy consumption

Appareils domestiques produisant de l'eau chaude
sanitaire utilisant les combustibles gazeux - Partie 2:
Evaluation de la consommation énergétique

Gasbefeuerte Geräte zur Warmwasserbereitung für
den Hausgebrauch - Teil 2: Bewertung des
Energieverbrauchs

This draft European Standard is submitted to CEN members for formal vote. It has been drawn up by the Technical Committee CEN/TC 109.

If this draft becomes a European Standard, CEN members are bound to comply with the CEN/CENELEC Internal Regulations which stipulate the conditions for giving this European Standard the status of a national standard without any alteration.

This draft European Standard was established by CEN in three official versions (English, French, German). A version in any other language made by translation under the responsibility of a CEN member into its own language and notified to the CEN-CENELEC Management Centre has the same status as the official versions.

CEN members are the national standards bodies of Austria, Belgium, Bulgaria, Croatia, Cyprus, Czech Republic, Denmark, Estonia, Finland, Former Yugoslav Republic of Macedonia, France, Germany, Greece, Hungary, Iceland, Ireland, Italy, Latvia, Lithuania, Luxembourg, Malta, Netherlands, Norway, Poland, Portugal, Romania, Serbia, Slovakia, Slovenia, Spain, Sweden, Switzerland, Turkey and United Kingdom.

Recipients of this draft are invited to submit, with their comments, notification of any relevant patent rights of which they are aware and to provide supporting documentation.

Warning : This document is not a European Standard. It is distributed for review and comments. It is subject to change without notice and shall not be referred to as a European Standard.



EUROPEAN COMMITTEE FOR STANDARDIZATION
COMITÉ EUROPÉEN DE NORMALISATION
EUROPÄISCHES KOMITEE FÜR NORMUNG

CEN-CENELEC Management Centre: Rue de la Science 23, B-1040 Brussels

Contents

Page

European foreword.....	4
Introduction	5
1 Scope.....	6
2 Normative references.....	6
3 Terms and definitions	6
4 General test conditions	8
4.1 Reference conditions	8
4.2 Measurement uncertainties	8
4.2.1 General.....	8
4.2.2 Steady state conditions	9
4.3 Test conditions.....	9
4.3.1 General.....	9
4.3.2 Test room.....	9
4.3.3 Water supply.....	9
4.3.4 Initial adjustment of the appliance.....	10
4.3.5 Conditions for the determination of the maximum load profile.....	10
4.3.6 Electrical supply	10
5 Determination of the energy consumption of the appliance.....	11
5.1 General.....	11
5.2 Load profiles	11
5.3 Determination of the energy recovered by the useful water	18
5.4 Calculation of gas energy	19
5.4.1 Calculation of daily gas energy consumption in summer mode.....	19
5.4.2 Calculation of daily gas energy consumption in winter mode.....	19
5.4.3 Daily gas energy consumption seasonally weighted.....	20
5.5 Calculation of daily electrical energy consumption	20
5.6 Measurement of energy consumption in standby mode.....	21
5.6.1 General.....	21
5.6.2 Calculation of daily gas energy consumption in standby mode	21
5.6.3 Calculation of daily auxiliary electrical energy consumption in standby mode	22
5.7 Determination of daily auxiliary electrical energy consumption in off mode.....	22
6 Determination of the ratio of wasted water to total water	22
7 Eco design Related Products Data.....	23
7.1 Water heating energy efficiency	23
7.2 Annual fuel consumption (AFC).....	24
7.3 Annual electricity consumption (AEC)	25
7.4 Mixed water at 40°C (V40) for storage water heaters	25
Annex A (informative) Test conditions	28
Annex B (informative) Test rig and measurement devices	31
B.1 General.....	31
B.2 Pressure measurement.....	32
B.3 Temperature measurement.....	32

Annex C (informative) Declaration of the Maximum Load Profile.....	36
Annex ZA (informative) Relationship between this European Standard and the ecodesign requirements of Commission Regulation (EU) n° 814/2013 [OJEU L239 of 6 September 2013] aimed to be covered.....	37
Annex ZB (informative) Relationship between this European Standard and the energy labelling requirements of Commission Delegated Regulation (EU) No 812/2013 [OJEU L239 of 6 September 2013] aimed to be covered.....	38
Annex ZC (informative) Relationship between this European Standard and the ecodesign requirements of Commission Regulation (EU) n° 813/2013 [OJEU L239 of 6 September 2013] aimed to be covered.....	39
Annex ZD (informative) Relationship between this European Standard and the energy labelling requirements of Commission Delegated Regulation (EU) No 811/2013 [OJEU L239 of 6 September 2013] aimed to be covered.....	40
Bibliography	41

European foreword

This document (FprEN 13203-2:2018) has been prepared by Technical Committee CEN/TC 109 "Central heating boilers using gaseous fuels", the secretariat of which is held by NEN.

This document is currently submitted to the Formal Vote.

This document will supersede EN 13203-2:2015.

The main purpose of this revision is to provide a means of conforming to requirements of Commission Delegated Regulation (EC) n° 813/2013, (EC) n° 811/2013, (EC) n° 812/2013 and (EC) n° 814/2013.

This document has been prepared under a mandate given to CEN by the European Commission and the European Free Trade Association, and supports essential requirements of EU Regulation(s).

Introduction

The safety operation of the boiler or water heater is not covered by this standard. Safety should be proved by means of the essential safety requirements of the Gas Appliances Regulation 2016/426/UE. This may be achieved by compliance with the appropriate existing harmonized standards.

NOTE Useful standards are EN 26, EN 89, EN 15502-1, EN 15502-2-1 and EN 15502-2-2.

1 Scope

This document is applicable to gas-fired appliances producing domestic hot water. It applies to both instantaneous and storage tank appliances; waters-heaters and combination boilers that have:

- a heat input not exceeding 400 kW; and
- a hot water storage tank capacity (if any) not exceeding 2000 l.

In the case of combination boilers, with or without storage tank, domestic hot water production is integrated or coupled, the whole being marketed as a single unit.

EN 13203-1 sets out in qualitative and quantitative terms the performance in delivery of domestic hot water for a selected variety of uses. It also gives a system for presenting the information to the user. The present document sets out a method for assessing the energy performance of the appliances. It defines a number of daily load profiles for each domestic hot water use, kitchen, shower, bath and a combination of these, together with corresponding test procedures, enabling the energy performances of different gas-fired appliances to be compared and matched to the needs of the user. Where other technologies are combined with a gas-fired boiler or a water heater to produce domestic hot water, specific parts of EN 13203 apply.

2 Normative references

There are no normative references in this document.

3 Terms and definitions

For the purposes of this document, the following terms and definitions apply.

ISO and IEC maintain terminological databases for use in standardization at the following addresses:

- IEC Electropedia: available at <http://www.electropedia.org/>
- ISO Online browsing platform: available at <http://www.iso.org/obp>

3.1

storage tank

reservoir for domestic hot water

3.2

nominal domestic hot water heat input (Q_{nw})

value of the heat input for the production of domestic hot water stated in the instructions

- Symbol: Q_{nw}
- Unit: kilowatt (kW)

3.3

summer mode

conditions during which the appliance supplies energy only for the production of domestic hot water

3.4

winter mode

conditions during which the combination boiler supplies energy for the production of domestic hot water and space heating

3.5**domestic water test temperature**

temperature of the delivered water at which the tests are conducted

3.6**control cycle**

the time cycle for keeping components and/or the storage tank (if any) of the domestic hot water circuit at predetermined temperature level, consists of an «ON» duration time during which the heating of the domestic hot water (by gas energy and/or auxiliary energy) is operating, and an «OFF» duration time during which no heating occurs

3.7**useful water**

quantity of water delivered at the tap for which the temperature increase is in accordance with the requirement fixed for each individual delivery of the load profiles

3.8**wasted water**

quantity of water delivered at the tap for which the temperature increase is not in accordance with the requirement fixed for each individual delivery of the load profiles

3.9**stand by mode**

operating state in which the appliance can provide domestic hot water at any time

Note 1 to entry: In the case of an appliance with a control cycle for keeping components and/or the storage tank (if any) of the domestic hot water circuit at predetermined temperature level no draw-off is made.

3.10**off mode**

state of an appliance, selected by the user, in which domestic hot water cannot be provided

3.11**useful water flow rate (D_{useful})**

quantity of water delivered by unit time at the tap for which the temperature increase is in accordance with the requirement fixed for each individual draw-off of the load profiles

3.12**useful water temperature**

water temperature, expressed in degrees Celsius, delivered at the tap

3.13**appliance flow rate**

quantity of water delivered by the appliance by unit time before the mixing device, if applicable

3.14**appliance water temperature (T_d)**

water temperature, expressed in degrees Celsius, delivered by the appliance before the mixing device

3.15**water temperature rise (ΔT_m) in K**

difference between the useful water temperature and the cold water temperature, at which hot water is contributing to the reference energy as specified in the load profiles

3.16

water temperature rise for basin draw-off types (ΔT_p) in K

difference between the useful water temperature and the cold water temperature, to be achieved during the water draw-offs, with a minimum value as specified in the load profiles

Note 1 to entry: The minimum temperature difference for basin draw-offs as specified in the load profiles shall be achieved at least once during the water draw-offs.

3.17

rapid response temperature sensor

measuring instrument with a response time such that 90 % of the final temperature rise, from 15 °C to 100 °C, is obtained within about 1 s, when the sensor is plunged into still water

4 General test conditions

4.1 Reference conditions

Unless otherwise stated, the general test conditions shall be as follows:

- cold water temperature: 10 °C;
 - maximum average variation over the test period: ± 2 K;
- cold water pressure: $(2 \pm 0,1)$ bar;
- ambient air temperature: 20 °C;
 - maximum average variation over the test period ± 2 K;
 - maximum individual variation during the tests ± 2 K;
- electrical supply voltage: (230 ± 2) V (single phase).

4.2 Measurement uncertainties

4.2.1 General

Except where otherwise stated in the clauses describing the tests, the uncertainties of measurements carried out shall not be greater than the maximum uncertainties indicated below.

The standard deviations shall be evaluated taking into account the various sources of uncertainty: contribution from the instrument, repeatability, calibration, ambient conditions, etc.

- water flow rate: ± 1 %;
- gas flow rate: ± 1 %;
- time: $\pm 0,2$ s;
- temperatures:
 - ambient: ± 1 K;
 - water: $\pm 0,5$ K;
 - gas: $\pm 0,5$ K;

- gas pressure: $\pm 1 \%$;
- gas calorific value: $\pm 1 \%$;
- gas density: $\pm 0,5 \%$;
- electrical energy: $\pm 2 \%$.

The stated measurement uncertainties relate to individual measurements. For measurements that combine a number of individual measurements, smaller uncertainties on the individual measurements may be necessary to ensure a total uncertainty within $\pm 2 \%$ under the steady state conditions as defined by 4.2.2.

These uncertainties correspond to two standard deviations (2σ).

4.2.2 Steady state conditions

Steady state operating conditions are regarded as established when the appliance operates for sufficient time to reach thermal stabilization.

To reach the steady state the water temperature at the outlet of the appliance shall not vary by more than $\pm 0,5$ K.

NOTE This condition can be reached with a gas which is different from the reference gas, provided that the appliance is supplied with the reference gas for at least 5 min before the requirements are verified.

4.3 Test conditions

4.3.1 General

Except where otherwise stated, the appliance is tested under the following conditions.

For combination gas boiler, the tests shall be carried out only in summer mode as defined in 3.3, and the appliance shall be set in summer mode.

For all tests defined by this standard, the same adjustment of the appliance shall be maintained.

The load profile used for the measurement shall be the one declared according to the technical instruction of the appliance (see also Annex C).

The tests shall be performed in the setting in which the appliance is delivered, and which is documented as such in the technical instructions.

If there are temporary user's settings (automatically self-resetting within 24 h), these shall not be active.

4.3.2 Test room

The appliance shall be installed in a well-ventilated, draught-free room (air speed less than 0,5 m/s).

The appliance shall be protected from direct solar radiation and radiation from heat generators.

4.3.3 Water supply

For the tests:

- the domestic water pressure is the static inlet pressure under dynamic conditions measured as close as possible to the appliance (see Figure B.2);
- the inlet and outlet temperatures of the domestic water shall be measured in the centre of the flow and as close as possible to the appliance (see Figure B.3) or at the tap.

The inlet temperatures shall be measured immediately upstream of the water inlet connection. Except where otherwise stated, the outlet temperatures shall be measured immediately downstream of the outlet connection or, in the case of an appliance with spout delivery, by means of an immersed temperature measuring device, e.g. a u-tube fitted at the outlet of a tube of the same length as the minimum length of the spout normally supplied together with the appliance.

Water temperatures shall be measured with a rapid response temperature sensor.

4.3.4 Initial adjustment of the appliance

The appliance shall be installed in accordance with the installation instructions.

The heat input shall be adjusted to within $\pm 2\%$ of the nominal domestic hot water heat input.

The adjustment of the appliance water temperature (T_d) shall be as follows (see Figure A.1 and Figure A.2):

- a) Appliances with an adjustable temperature: the tests shall be carried out at a temperature not greater than 65 °C, with a minimum temperature increase of 45 K above the water inlet temperature. For the load profile XS the minimum temperature setting shall be equal to or greater than 35°C (ΔT 25 K above water inlet temperature).
- b) Appliances with a fixed temperature: the tests shall be carried out at the temperature specified in the appliance documentation, with a minimum temperature increase of 45 K above the water inlet temperature. For the load profile XS the minimum temperature setting shall be equal to or greater than 35°C (ΔT 25 K above water inlet temperature)

NOTE The test conditions of 4.3.1 are applicable.

The same conditions of initial adjustment stated in the appliance documentation shall be used for all the tests. These conditions shall be included in the test report.

4.3.5 Conditions for the determination of the maximum load profile

The measurement of the domestic hot water efficiency shall be performed with the maximum load profile or the one just below this load profile:

- a) Instantaneous appliances shall be set to the nominal heat input as stated on the data plate. If the user instructions specify that it is possible to adjust the outlet temperature, this temperature shall be set to the maximum possible value not exceeding 65°C.
- b) Storage appliances shall be set to the nominal heat input as stated on the data plate. If the user instructions specify that different modes are possible to be selected, the one that is able to store more energy and that delivers more hot water during a 24 hours period shall be used.

NOTE 1 See Annex C (informative).

NOTE 2 In case of declared maximal load profile 3XL or 4XL the load profile for testing should be XXL.

The load profile as used for the domestic hot water performance test shall be stated in the user instructions.

4.3.6 Electrical supply

The appliance shall be supplied with the nominal voltage stated in the installation instructions.

5 Determination of the energy consumption of the appliance

5.1 General

This clause defines the test methods to be employed in determining the energy consumption of appliances.

5.2 Load profiles

All patterns define a 24 h measurement cycle and within that cycle the starting times and the total energy content (in kWh equivalent of hot water tapped) of each draw-off are defined.

Furthermore, the draw-off can be characterized in two ways, either “basin” type draw-off versus “continuous flow” draw-off.

The aim of the “basin” type is to arrive at an average temperature of the tub, so all supplied energy can be considered useful from the very beginning of the draw-off (minimum useful temperature rise is 0 K). The temperature rise (ΔT_p) to be achieved during tapping, shall be 30 K for floor cleaning and bath and 45 K for the dish washes.

The aim of the “continuous flow” type is to use only the water with a minimum temperature. For the shower, household cleaning and large draw-offs a temperature rise of 30 K shall be reached before counting the useful energy. For the small draw-offs a temperature rise (ΔT_m) of 15 K shall be reached.

NOTE 1 The temperature rises (in K) based on 10 °C inlet water temperature stated above are equivalent to the temperatures (in °C) given by the load profiles tables in Regulations n° 811/2013, n° 812/2013, n° 813/2013 and n° 814/2013. The tapping flow rates used to perform the different draw-offs of each of the eight load profiles are defined by Tables 1 to 8.

When these water draw-off flow rates result in a tapping period of less than 15 s the water flow rate should be decreased such that the tapping period is (16 ± 1) s.

In the load profiles, the requirements for water flow rate and temperatures are based on the delivery at the tap in a mix of hot and cold water. Under the conditions of the initial adjustment, the appliance itself produces hot water with a minimum temperature rise of 45 K. For the load profile XS the minimum temperature setting shall be equal to or greater than 35°C (ΔT 25 K above water inlet temperature).

To fulfil the requirements stated in Tables 1 to 8 mixing hot water from the appliance with cold water of 10 °C at the tap is allowed either by using a mixing device (see Figures B.1 and B.5) or by recalculating the appliance flow rate (D_{\min}) according to the following formula:

$$D_{\min} = D_{\text{useful}} \frac{\Delta T_{\text{useful}}}{\Delta T_d} \quad (1)$$

where

- D_{\min} is the minimum test rig setting for the appliance flow rate of each individual draw-off at temperature rise corresponding to ΔT_d , in l/min;
- D_{useful} is the useful water flow rate according to Tables 1 to 8, in l/min;
- ΔT_d is the appliance water temperature rise, with a minimum of 30 K;
- ΔT_{useful} is the higher value between the temperature rise to be achieved and the minimum temperature rise for counting the useful energy according to Tables 1 to 8.

If the appliance cannot deliver these flow rates, for instance due to the flow restrictor, it shall be checked that the requirements are fulfilled by checking that (D_{\min}) is delivered.

If by design the appliance is fitted with a flow restrictor, the tests shall be carried out with this flow restrictor.

The tests shall be performed by using the useful water flow rates defined by Tables 1 to 8.

Table 1 — Load profile XS

Draw-off n°	Start (h:min)	Energy (kWh)	Type of draw-off	Useful water flow rate at the tap (l/min)	ΔT_p to be achieved during tapping (K)	Minimum ΔT_m for counting useful energy (K)
1	07:30	0,525	Medium	3		25
2	12:45	0,525	Medium	3		25
3	20:30	1,050	Large	3		25
Q_{ref}		2,100				

Equivalent hot water litres at 60°C

36

Table 2 — Load profile S

Draw-off n°	Start (h:min)	Energy (kWh)	Type of draw-off	Useful water flow rate at the tap (l/min)	ΔT_p to be achieved during tapping (K)	Minimum ΔT_m for counting useful energy (K)
1	07:00	0,105	Small	3		15
2	07:30	0,105	Small	3		15
3	08:30	0,105	Small	3		15
4	09:30	0,105	Small	3		15
5	11:30	0,105	Small	3		15
6	11:45	0,105	Small	3		15
7	12:45	0,315	Dish washing n°1	4	45	0
8	18:00	0,105	Small	3		15
9	18:15	0,105	Household cleaning	3		30
10	20:30	0,420	Dish washing n°2	4	45	0
11	21:30	0,525	Large	5		35
Q_{ref}		2,100				

Equivalent hot water litres at 60°C

36

Table 3 — Load profile M

Draw-off n°	Start (h:min)	Energy (kWh)	Type of draw-off	Useful water flow rate at the tap (l/min)	ΔT_p to be achieved during tapping (K)	Minimum ΔT_m for counting useful energy (K)
1	07:00	0,105	Small	3		15
2	07:05	1,400	Shower n°1	6		30
3	07:30	0,105	Small	3		15
4	08:01	0,105	Small	3		15
5	08:15	0,105	Small	3		15
6	08:30	0,105	Small	3		15
7	08:45	0,105	Small	3		15
8	09:00	0,105	Small	3		15
9	09:30	0,105	Small	3		15
10	10:30	0,105	Floor cleaning	3	30	0
11	11:30	0,105	Small	3		15
12	11:45	0,105	Small	3		15
13	12:45	0,315	Dish washing n°1	4	45	0
14	14:30	0,105	Small	3		15
15	15:30	0,105	Small	3		15
16	16:30	0,105	Small	3		15
17	18:00	0,105	Small	3		15
18	18:15	0,105	Household cleaning	3		30
19	18:30	0,105	Household cleaning	3		30
20	19:00	0,105	Small	3		15
21	20:30	0,735	Dish washing n°3	4	45	0
22	21:15	0,105	Small	3		15
23	21:30	1,400	Shower n°1	6		30
Q_{ref}		5,845				

Equivalent hot water litres at 60 °C

100,2

Table 4 — Load profile L

Draw-off n°	Start (h:min)	Energy (kWh)	Type of draw-off	Useful water flow rate at the tap (l/min)	ΔT_p to be achieved during tapping (K)	Minimum ΔT_m for counting useful energy (K)
1	07:00	0,105	Small	3		15
2	07:05	1,400	Shower n°1	6		30
3	07:30	0,105	Small	3		15
4	07:45	0,105	Small	3		15
5	08:05	3,605	Bath n°1	10	30	0
6	08:25	0,105	Small	3		15
7	08:30	0,105	Small	3		15
8	08:45	0,105	Small	3		15
9	09:00	0,105	Small	3		15
10	09:30	0,105	Small	3		15
11	10:30	0,105	Floor cleaning	3	30	0
12	11:30	0,105	Small	3		15
13	11:45	0,105	Small	3		15
14	12:45	0,315	Dish washing n°1	4	45	0
15	14:30	0,105	Small	3		15
16	15:30	0,105	Small	3		15
17	16:30	0,105	Small	3		15
18	18:00	0,105	Small	3		15
19	18:15	0,105	Household cleaning	3		30
20	18:30	0,105	Household cleaning	3		30
21	19:00	0,105	Small	3		15
22	20:30	0,735	Dish washing n°3	4	45	0
23	21:00	3,605	Bath n°1	10	30	0
24	21:30	0,105	Small	3		15
Q_{ref}		11,655				

Equivalent hot water litres at 60 °C

199,8

Table 5 — Load profile XL

Draw-off n°	Start (h:min)	Energy (kWh)	Type of draw-off	Useful water flow rate at the tap (l/min)	ΔT_p to be achieved during tapping (K)	Minimum ΔT_m for counting useful energy (K)
1	07:00	0,105	Small	3		15
2	07:15	1,820	Shower n°2	6		30
3	07:26	0,105	Small	3		15
4	07:45	4,420	Bath n°2	10	30	0
5	08:01	0,105	Small	3		15
6	08:15	0,105	Small	3		15
7	08:30	0,105	Small	3		15
8	08:45	0,105	Small	3		15
9	09:00	0,105	Small	3		15
10	09:30	0,105	Small	3		15
11	10:00	0,105	Small	3		15
12	10:30	0,105	Floor cleaning	3	30	0
13	11:00	0,105	Small	3		15
14	11:30	0,105	Small	3		15
15	11:45	0,105	Small	3		15
16	12:45	0,735	Dish washing n°3	4	45	0
17	14:30	0,105	Small	3		15
18	15:00	0,105	Small	3		15
19	15:30	0,105	Small	3		15
20	16:00	0,105	Small	3		15
21	16:30	0,105	Small	3		15
22	17:00	0,105	Small	3		15
23	18:00	0,105	Small	3		15
24	18:15	0,105	Household cleaning	3		30
25	18:30	0,105	Household cleaning	3		30
26	19:00	0,105	Small	3		15
27	20:30	0,735	Dish washing n°3	4	45	0
28	20:46	4,420	Bath n°2	10	30	0
29	21:15	0,105	Small	3		15
30	21:30	4,420	Bath n°2	10	30	0
Q_{ref}		19,070				

Equivalent hot water litres at 60°C

325

Table 6 — Load profile XXL

Draw-off n°	Start (h:min)	Energy (kWh)	Type of draw-off	Useful water flow rate at the tap (l/min)	ΔT_p to be achieved during tapping (K)	Minimum ΔT_m for counting useful energy (K)
1	07:00	0,105	Small	3		15
2	07:15	1,820	Shower n°2	6		30
3	07:26	0,105	Small	3		15
4	07:45	6,240	Shower + bath	16	30	0
5	08:01	0,105	Small	3		15
6	08:15	0,105	Small	3		15
7	08:30	0,105	Small	3		15
8	08:45	0,105	Small	3		15
9	09:00	0,105	Small	3		15
10	09:30	0,105	Small	3		15
11	10:00	0,105	Small	3		15
12	10:30	0,105	Floor cleaning	3	30	0
13	11:00	0,105	Small	3		15
14	11:30	0,105	Small	3		15
15	11:45	0,105	Small	3		15
16	12:45	0,735	Dish washing n°3	4	45	0
17	14:30	0,105	Small	3		15
18	15:00	0,105	Small	3		15
19	15:30	0,105	Small	3		15
20	16:00	0,105	Small	3		15
21	16:30	0,105	Small	3		15
22	17:00	0,105	Small	3		15
23	18:00	0,105	Small	3		15
24	18:15	0,105	Household cleaning	3		30
25	18:30	0,105	Household cleaning	3		30
26	19:00	0,105	Small	3		15
27	20:30	0,735	Dish washing n°3	4	45	0
28	20:46	6,240	Shower + bath	16	30	0
29	21:15	0,105	Small	3		15
30	21:30	6,240	Shower + bath	16	30	0
Q_{ref}		24,530				

Equivalent hot water litres at 60 °C

420

Table 7 — Load profile 3XL

Draw-off n°	Start (h:min)	Energy (kWh)	Type of draw-off	Useful water flow rate at the tap (l/min)	ΔT_p to be achieved during tapping (K)	Minimum ΔT_m for counting useful energy (K)
1	07:00	11,2	General use n°3	48		30
2	08:01	5,04	General use n°8	24		15
3	09:00	1,68	General use n°9	24		15
4	10:30	0,84	General use n°10	24	30	0
5	11:45	1,68	General use n°9	24		15
6	12:45	2,52	General use n°11a	32	45	0
7	15:30	2,52	General use n°11	24		15
8	18:30	3,36	General use n°12	24		15
9	20:30	5,88	General use n°13	32	45	0
10	21:30	12,04	General use n°5	48		30
Q_{ref}		46,76				

Equivalent hot water litres at 60 °C

800

Table 8 — Load profile 4XL

Draw-off n°	Start (h:min)	Energy (kWh)	Type of draw-off	Useful water flow rate at the tap (l/min)	ΔT_p to be achieved during tapping (K)	Minimum ΔT_m for counting useful energy (K)
1	07:00	22,4	General use n°6	96		30
2	08:01	10,08	General use n°2	48		15
3	09:00	3,36	General use n°12a	48		15
4	10:30	1,68	General use n°9a	48	30	0
5	11:45	3,36	General use n°12a	48		15
6	12:45	5,04	General use n°8b	64	45	0
7	15:30	5,04	General use n°8a	48		15
8	18:30	6,72	General use n°1	48		15
9	20:30	11,76	General use n°4	64	45	0
10	21:30	24,08	General use n°7	96		30
Q_{ref}		93,52				

Equivalent hot water litres at 60 °C

1600

There are eight different load profiles, depending on the use.

For each use, the load profile(s) is (are) based respectively on Tables 1 to 8. Each individual draw-offs of the load profiles shall be completed, that means the valve shall be closed, and a delay of at least one minute is required, before starting the following delivery.

Beginning and ending of the load profiles:

- for appliances with no energy consumption between deliveries (neither gas nor electricity), the measured programme starts at 07h00 with the appliance cold and finishes when the burner is extinguished after the 21h30 tapping (see Figure A.3).
- for appliances with energy consumption between deliveries (either gas or electricity or both), the tappings start with the tapping at 21h30. The measured cycle starts from the time the burner is extinguished following the 21h30 delivery. The measured cycle ends when the burner is extinguished following the last tapping at 21h30 on the next day.

It shall be ensured that the energy content at the beginning and at the end of the test is the same.

NOTE 2 The above indicated test conditions ensure that the test results are equivalent to the required measurement conditions of Regulations n° 811/2013, n° 812/2013, n° 813/2013 and n° 814/2013.

NOTE 3 This measurement can be performed after a 24 h preliminary load profile in order to ensure the thermal stabilization.

NOTE 4 The energy not directly used for water heating (for example: standby, pilot flame) will be considered as energy consumption.

5.3 Determination of the energy recovered by the useful water

The appliance shall be installed and adjusted in the initial state conditions and in the initial adjustment conditions defined in 4.3.4.

The useful energy recovered by the water Q_{H_2O} (kWh) is given according to the following formula:

$$Q_{H_2O} = c_w \sum_{i=1}^n \int_0^{t_i} D_i \cdot \Delta T_i(t) dt \quad (2)$$

where

N is the number of draw-offs;

D_i is the water flow rate delivered at the tap, in l/min;

$\Delta T_i(t)$ is the instantaneous temperature rise during the tapping, in K;

t_i is the tapping duration of the useful water, in min;

c_w is the specific heat capacity of water ($1,163 \cdot 10^{-3}$ kWh/l.K).

The useful energy recovered at each individual draw-off shall be set against the values given in Tables 1 to 8.

For each individual draw-off, the accuracy of the value shall be ± 10 Wh or \pm within 2 % of the energy content of this specific individual draw-off. For the overall load profile the accuracy of the value shall be within ± 2 %.

5.4 Calculation of gas energy

5.4.1 Calculation of daily gas energy consumption in summer mode

The daily gas energy consumption in summer mode shall be calculated according to the following formula:

$$Q_{\text{gas,S}} = \frac{V_g \cdot K \cdot \text{NCV} \cdot Q_{\text{ref}}}{Q_{\text{H}_2\text{O}}} \quad (3)$$

where

$Q_{\text{gas,S}}$ is the daily gas energy consumption in summer mode calculated using NCV, in kWh;

V_g is the measured gas consumption during the load profile, in m³;

NCV is the net calorific value (at 15 °C and 1013,25 mbar), in kWh/m³;

$Q_{\text{H}_2\text{O}}$ is the measured energy recovered by the water according to 5.3, in kWh;

Q_{ref} is the total delivered energy by the load profile, value from Tables 1 to 8, in kWh.

and

$$K = \frac{p_a + p_g}{1013,25} \cdot \frac{288,15}{T_g + 273,15} \quad (4)$$

where

p_a is the atmospheric pressure, in mbar;

p_g is the gas pressure, in mbar;

T_g is the gas temperature, in °C.

5.4.2 Calculation of daily gas energy consumption in winter mode

For all water heaters $Q_{\text{gas,W}}$ is equal to $Q_{\text{gas,S}}$.

For the combination boilers, with a heat input above 70 kW, $Q_{\text{gas,W}}$ is equal to $Q_{\text{gas,S}}$

For the combination boilers, with storage capacity above 500 l, $Q_{\text{gas,W}}$ is equal to $Q_{\text{gas,S}}$.

For the combination boilers, with heat input below 70 kW and with storage capacity below 500 l, the daily gas energy consumption in winter mode shall be calculated according to the following formula:

$$Q_{\text{gas,W}} = \frac{Q_{\text{gas,S}}}{1 + 0,5 \cdot \left[\frac{\eta_{\text{CH-nom}} \times Q_{\text{gas,S}}}{Q_{\text{ref}}} - 1 \right]} \quad (5)$$

where

$Q_{\text{gas,W}}$ is the daily gas energy consumption calculated in winter mode using NCV, in kWh;

$Q_{\text{gas,S}}$ is the daily gas energy consumption calculated in summer mode using NCV according to 5.4.1, in kWh;

η_{CH-nom} is the useful efficiency at nominal heat input and at an average temperature of 70 °C for the space heating function;

Q_{ref} is the total energy delivered of the load profile used, value from Tables 1 to 8, in kWh.

NOTE Unlike water heaters combination boilers have two functions in the winter mode, space heating and domestic hot water. They switch between space heating and domestic hot water functions to fulfil demands as required by the control system.

In the summer mode the combination boiler is 24 h in domestic hot water mode or standby mode.

The combination boiler in winter mode spends most of the demand time on space heating, outside any night (or day) set-back periods (which require a lower room temperature and hence heating load).

When a combination boiler switches from space heating to domestic hot water mode and back to space heating the standby losses usually generated from the domestic hot water mode are not lost but are instead used in the space heating mode.

That means combination heaters have lower domestic hot water heat losses in winter mode than in summer mode.

These energy saving benefits of combination boilers will be taken into account.

5.4.3 Daily gas energy consumption seasonally weighted

The daily gas energy consumption is weighted, to take into account both summer and winter modes, by the following formula:

$$Q_{gas,p} = Q_{gas,W} \cdot \frac{D_W}{D_W + D_S} + Q_{gas,S} \cdot \frac{D_S}{D_W + D_S} \quad (6)$$

where

$Q_{gas,p}$ is the weighted daily gas energy consumption calculated using NCV, in kWh;

$Q_{gas,W}$ is the daily gas energy consumption calculated in winter mode using NCV, in kWh;

$Q_{gas,S}$ is the daily gas energy consumption in summer mode calculated using NCV, in kWh;

D_W is the number of days of winter mode, this number is equal to 200;

D_S is the number of days of summer mode, this number is equal to 165.

5.5 Calculation of daily electrical energy consumption

The daily electrical energy of all the electrical auxiliaries necessary to achieve the load profile(s) at nominal use as described in the appliance documentation will be measured even if these auxiliaries are not integrated in the appliance.

Where an electrical auxiliary (e.g. a pump) necessary for the delivery of hot water is not included as an integral part of the appliance, then the essential characteristics of the component shall be specified in the appliance installation instructions. An appropriate component shall be used for test procedures.

The measurement of the electrical consumption starts at the same time and finishes at the same time as the measurement of the gas consumption.

This measurement shall be corrected according to the following formula:

$$E_{\text{elecco}} = E_{\text{elecmes}} \cdot \frac{Q_{\text{ref}}}{Q_{\text{H}_2\text{O}}} \quad (7)$$

where

E_{elecco} is the corrected total electrical energy, in kWh;

E_{elecmes} is the measured total electrical energy, in kWh;

$Q_{\text{H}_2\text{O}}$ is the measured energy delivered to the water according to 5.3, in kWh;

Q_{ref} is the total delivered energy of used load profile, value from Tables 1 to 8, in kWh.

5.6 Measurement of energy consumption in standby mode

5.6.1 General

Unless specified, the consumed energy in standby mode shall be measured for a 24 h period without tapping.

However:

- for the appliances without a control cycle the gas and auxiliary energy consumption may be measured for a duration time equal to 1 h;
- for the appliances with repeated control cycles for a 24 h period, the gas and auxiliary energy consumption may be measured for a duration time (t_a) equal to one or several control cycles, once the appliance is operating in a regular manner (see Figure A.5).

5.6.2 Calculation of daily gas energy consumption in standby mode

The daily consumption of gas in standby mode shall be calculated according to the following formula:

$$Q_{\text{gas.stb}} = V_g \cdot K \cdot \text{NCV} \cdot \frac{24}{t_a} \quad (8)$$

where

$Q_{\text{gas.stb}}$ is the daily gas energy consumption in standby mode calculated using NCV, in kWh;

V_g is the measured gas consumption during the test, in m³;

NCV is the net calorific value (at 15 °C and 1013,25 mbar), in kWh/m³;

t_a is the duration of the test in hour ($t_a = 1$ h for the appliances without control cycle).

and

$$K = \frac{p_a + p_g}{1013,25} \cdot \frac{288,15}{T_g + 273,15} \quad (9)$$

where

p_a is the atmospheric pressure, in mbar;

p_g is the gas pressure, in mbar;

T_g is the gas temperature, in °C.

5.6.3 Calculation of daily auxiliary electrical energy consumption in standby mode

The daily auxiliary electrical energy consumption in standby mode shall be calculated according to the following formula:

$$E_{\text{elecco.stb}} = E_{\text{elecmes.stb}} \cdot \frac{24}{t_a} \quad (10)$$

where

$E_{\text{elecco.stb}}$ is the daily consumption of auxiliary energy in standby mode, in kWh;

$E_{\text{elecmes.stb}}$ is the auxiliary energy measured during the test in standby mode, in kWh;

t_a is the duration of the test in hour ($t_a = 1$ h for the appliances without control cycle).

5.7 Determination of daily auxiliary electrical energy consumption in off mode

The auxiliary electrical energy consumption in off mode is measured for a duration time equal to 1 h.

The daily auxiliary electrical energy consumption in off mode shall be calculated according to the following formula:

$$E_{\text{elecco.off}} = E_{\text{elecmes.off}} \cdot 24 \quad (11)$$

where

$E_{\text{elecco.off}}$ is the daily auxiliary electrical energy consumption in off mode, in kWh;

$E_{\text{elecmes.off}}$ is the auxiliary electrical energy consumption measured during the test in off mode, in kWh.

6 Determination of the ratio of wasted water to total water

The quantity of the useful water (V_u) is equal to the sum of the useful water quantities for the declared load profile of 5.2.

$$V_u = \sum_{i=1}^n \int_0^{t_{u,i}} d_i(t) dt \quad (12)$$

where

V_u is the total quantity of useful water, in l;

$d_i(t)$ is the water flow rate as a function of time, delivered, in l/min;

- $t_{u,i}$ is the tapping duration of the useful water, in min;
 i is the number of draw-off i in the load profile of 5.2;
 n is the last draw-off in the load profile of 5.2.

The quantity of the wasted water (V_w) is equal to the sum of the wasted water quantities for all draw-offs in the declared load profile of 5.2.

$$V_w = \sum_{i=1}^n \int_0^{t_{w,i}} d_i(t) dt \quad (13)$$

where

- V_w is the total quantity of wasted water, in l;
 $d_i(t)$ is the water flow rate as a function of time, delivered, in l/min;
 $t_{w,i}$ is the tapping duration of the wasted water in min;
 i is the number of draw-off in the load profile of 5.2;
 n is the last draw-off in the load profile of 5.2.

The ratio in % of the wasted water to the total water (R) is given by:

$$R = \frac{V_w}{V_u + V_w} \cdot 100 \quad (14)$$

where

- V_w is the total quantity of wasted water, in l;
 V_u is the total quantity of useful water, in l;
 R is the percentage of the wasted water.

7 Eco design Related Products Data

7.1 Water heating energy efficiency

The water heating energy efficiency (η_{wh}), in %, based on GCV and including primary energy for electricity is calculated as:

- For appliances without smart control:

$$\eta_{wh} = \frac{Q_{ref}}{(Q_{fuel} + CC \cdot E_{elec}) + Q_{cor}} \cdot 100 \quad (15)$$

- For appliances with smart control:

$$\eta_{wh} = \frac{Q_{ref}}{(Q_{fuel} + CC \cdot E_{elecco}) \cdot (1 - SCF \cdot smart) + Q_{cor}} \cdot 100 \quad (16)$$

where

- Q_{ref} is the total energy delivered by the load profile used, value from Tables 1 to 8, in kWh.
- CC is the conversion coefficient' (CC) means a coefficient reflecting the estimated average EU generation efficiency referred to in Directive 2006/32/EC of the European Parliament and of the Council¹⁶; the value of the conversion coefficient is $CC = 2,5$.
- E_{elecco} is the consumption of electricity for water heating over 24 consecutive hours under the declared load profile, expressed in kWh, in terms of final energy. See 5.5.
- Q_{fuel} is the daily fuel consumption for domestic hot water over 24 consecutive hours under the declared load profile, expressed in kWh, in terms of GCV.

where

$$Q_{fuel} = Q_{gas,S} \frac{GCV}{NCV} \quad (17)$$

where

- $Q_{gas,S}$ is the daily gas energy consumption in summer mode (kWh) calculated using Net Calorific Value (NCV). See 5.4.1;
- GCV is the gross calorific value (at 15 °C and 1013,25 mbar), in kWh/m³;
- NCV is the net calorific value (at 15 °C and 1013,25 mbar), in kWh/m³;
- SCF smart control factor (SCF) means the water heating energy efficiency gain due to smart control (see Regulation n°814/2013, Annex IV, Clause 4);
- $smart$ is the smart control coefficient, is equal to 0 without smart control or 1 with smart control;
- Q_{cor} is the ambient correction term, is equal to 0 for load profiles XXL to 4XL, and for load profiles XS to XL is equal to the following formula (18):

$$Q_{cor} = -0,23 \cdot (Q_{fuel} \cdot (1 - SCF \cdot smart) - Q_{ref}) \quad (18)$$

7.2 Annual fuel consumption (AFC)

The annual fuel consumption AFC in GJ in terms of GCV shall be calculated according to the following formula:

$$AFC = 0,6 \cdot (D_W + D_S) \cdot [Q_{fuel} \cdot (1 - SCF \cdot smart) + Q_{cor}] \cdot \frac{3,6}{1000} \quad (19)$$

where

- D_W is the number of days of winter mode, this number is equal to 200;
- D_S is the number of days of summer mode, this number is equal to 165;
- SCF smart control factor (SCF) means the water heating energy efficiency gain due to smart control (see Regulation n°814/2013, Annex IV, Clause 4);
- $smart$ is the smart control coefficient, is equal to 0 without smart control or 1 with smart control;

Q_{cor} is the ambient correction term, is equal to 0 for load profiles XXL to 4XL, or equal to the formula (18) for load profiles XS to XL.

NOTE Factor 0,6 represents the customer's hot water demand fraction over the year.

7.3 Annual electricity consumption (AEC)

The annual electricity consumption AEC in kWh shall be calculated according to the following formula:

$$AEC = 0,6 \cdot (D_w + D_s) \cdot \left[E_{elecco} \cdot (1 - SCF \cdot smart) + \frac{Q_{cor}}{CC} \right] \quad (20)$$

where

E_{elecco} is the consumption of electricity for water heating over 24 consecutive hours under the declared load profile, expressed in kWh in terms of final energy. See 5.5;

NOTE Factor 0,6 represents the customer's hot water demand fraction over the year.

7.4 Mixed water at 40°C (V40) for storage water heaters

This requirement applies only for storage water heaters according to EN 89.

The appliance is adjusted according to 4.3.4 with the exception to set the appliance water temperature to the maximum as stated by the user's instructions.

During the test appliance is operating normally.

The water flow rate at the appliance outlet (D_d) is set at to the following value according to the load profile stated in the technical documentation for the test.

Table 9 — Water flow rate (V40)

Load profile								
Water flow rate (l/min)								

Mixed water at 40 °C (V40) is the quantity of water at 40 °C, which has the same heat content (enthalpy) as the hot water which is delivered above 40 °C at the output of the water heater, expressed in litres (see Figure 1).

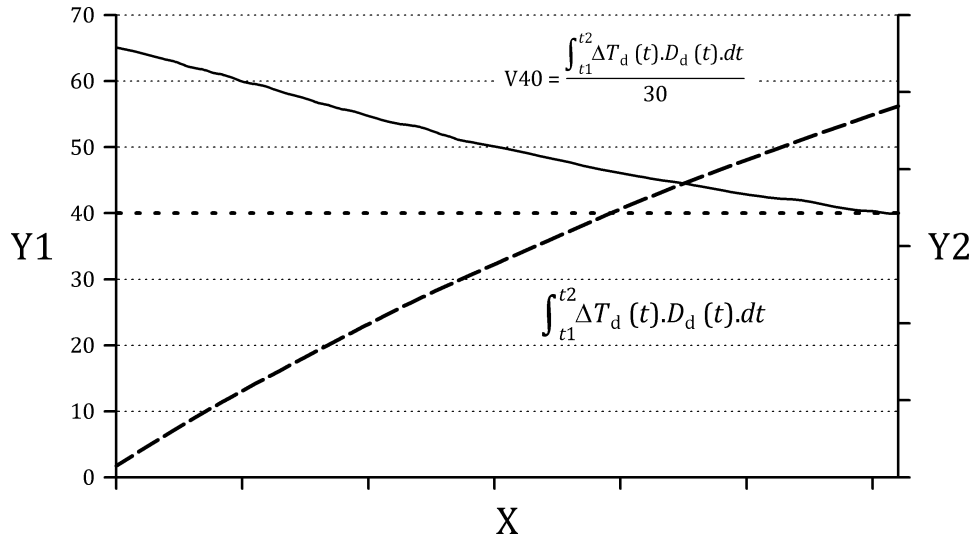

Key
 — T_d
 -- tapped energy
 X time
 Y1 temperature (°C)
 Y2 tapped energy

Figure 1 — Mixed water at 40°C (V40)

A draw-off is performed until the appliance water temperature rise falls below 30 K. The quantity of water is measured when the appliance temperature rise is above 30 K according to Figure 2.

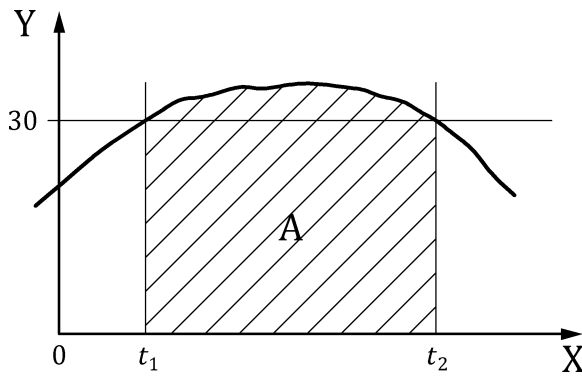

Key
 X time
 Y $\Delta T(u)$
 A enthalpy Q

Figure 2— Enthalpy calculation (V40)

V40 is calculated according to the following formula:

$$V_{40} = \frac{\int_{t_1}^{t_2} \Delta T_d(t) \cdot D_d(t) \cdot dt}{30} \quad (21)$$

where

$\Delta T_d(t)$ is the measured useful water temperature rise at the appliance outlet, in K;

$D_d(t)$ is the measured useful water flow rate at the appliance outlet, in l/min;

t_1, t_2 are respectively the starting time and closing time of the enthalpy calculation, in min.

Annex A
(informative)

Test conditions

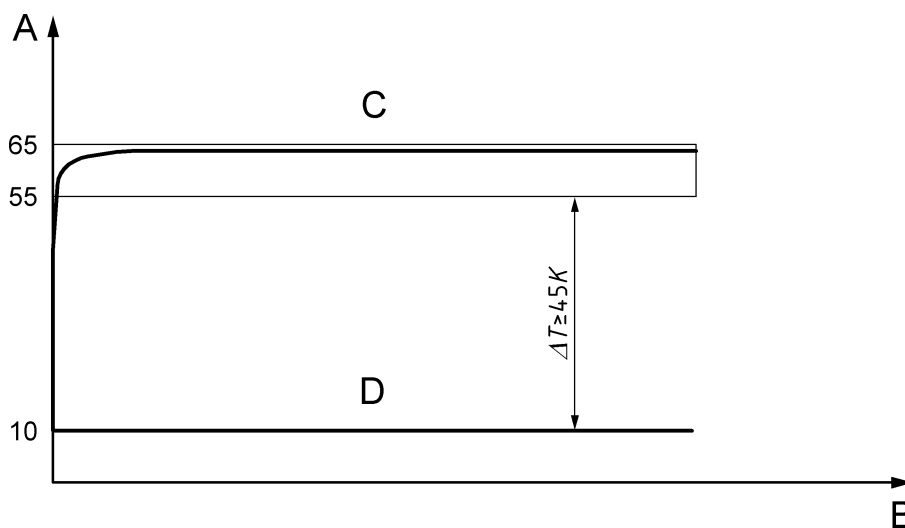

Key

- A temperature (°C)
- B time (min)
- C hot water
- D cold water

Figure A.1 — Initial adjustment of the appliance with storage tank maintained in temperature

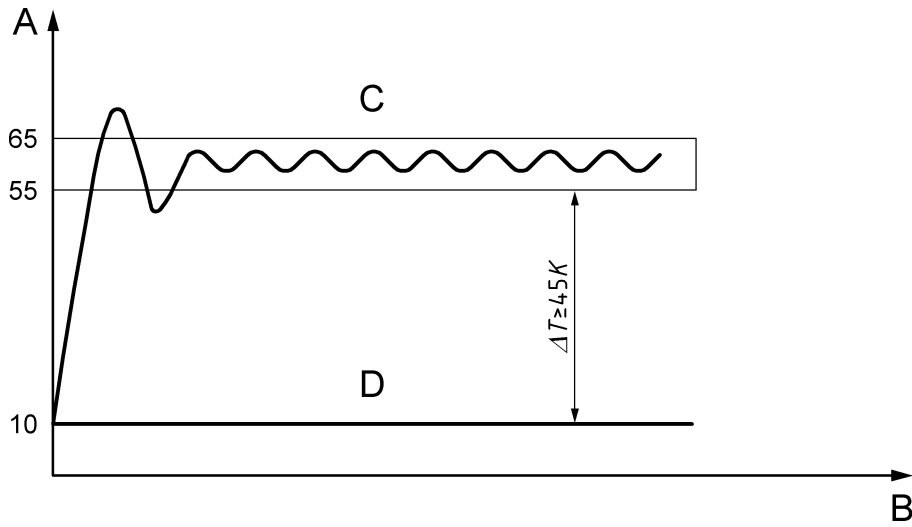

Key

- A temperature (°C)
- B time (min)
- C hot water
- D cold water

Figure A.2 — Initial adjustment of the appliance without storage tank maintained in temperature

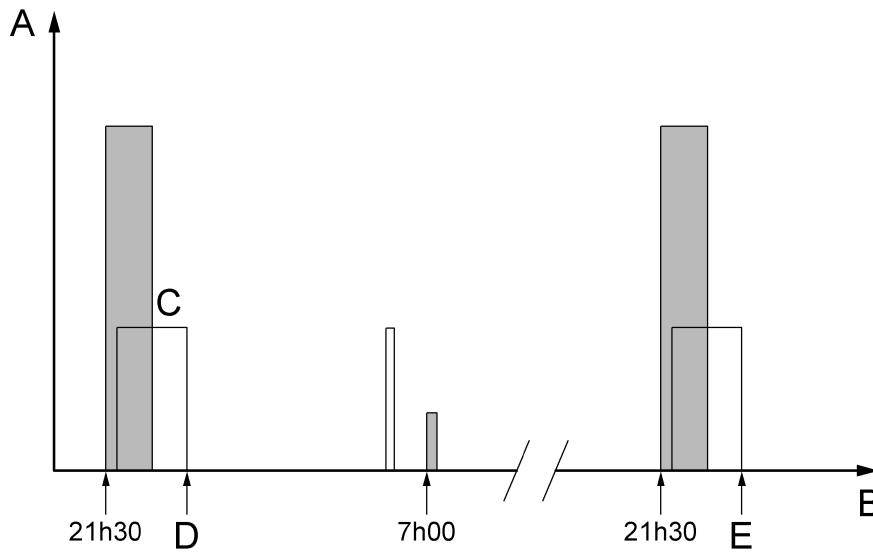

Key

- A delivered elementary energy (kWh)
- B time (h)
- C gas rate
- D beginning of the measurement programme
- E end of the measurement programme

Figure A.3 — Load profile – Test cycle for measurement of the energy consumption of the appliance with storage tank maintained in temperature

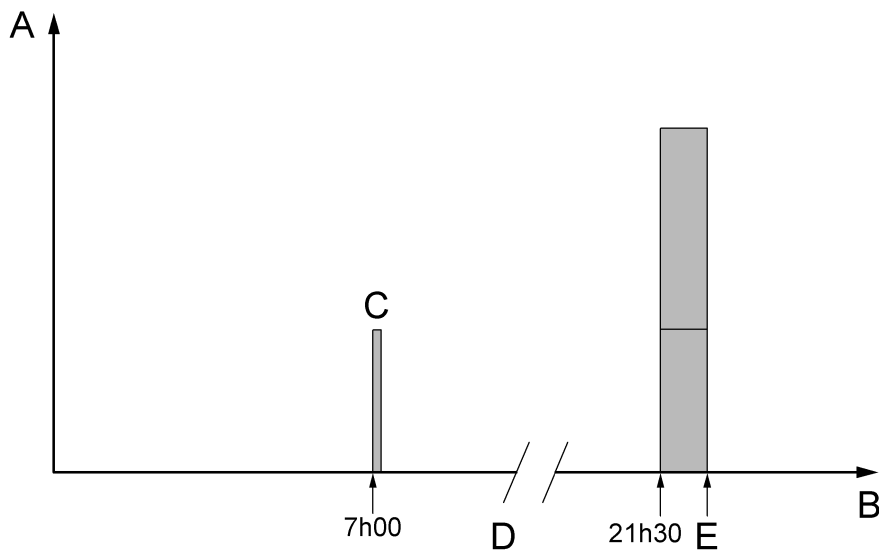

Key

- A delivered elementary energy (kWh)
- B time (h)
- C gas rate
- D beginning of the measurement programme
- E end of the measurement programme

Figure A.4 — Load profile - Test cycle for measurement of the energy consumption of the appliance without storage tank maintained in temperature

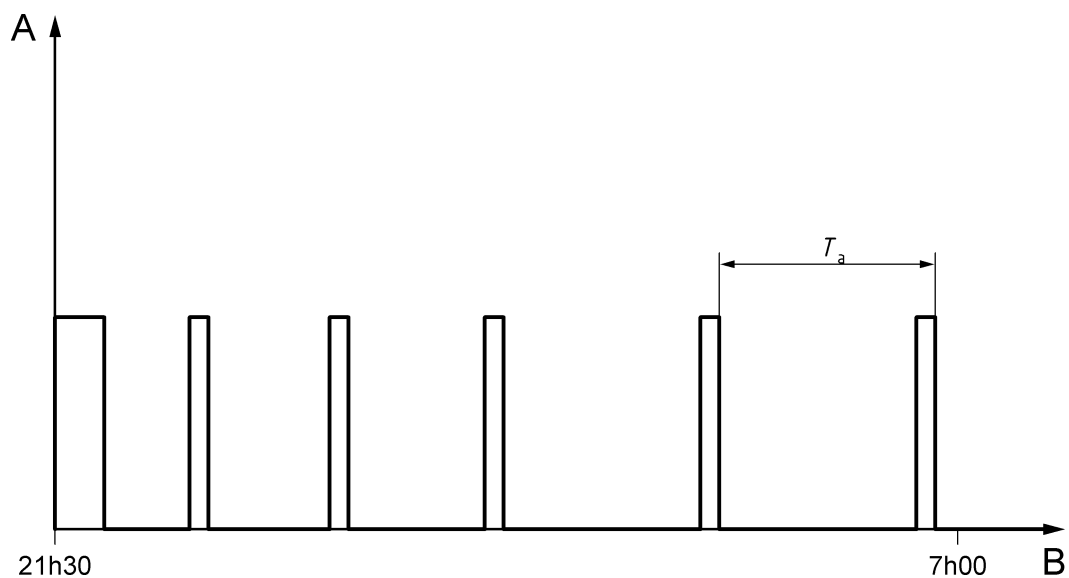

Key

- T_a test duration

Figure A.5 — Standby mode with control cycles

Annex B (informative)

Test rig and measurement devices

B.1 General

A general diagram of a possible test rig is shown in Figure B.1.

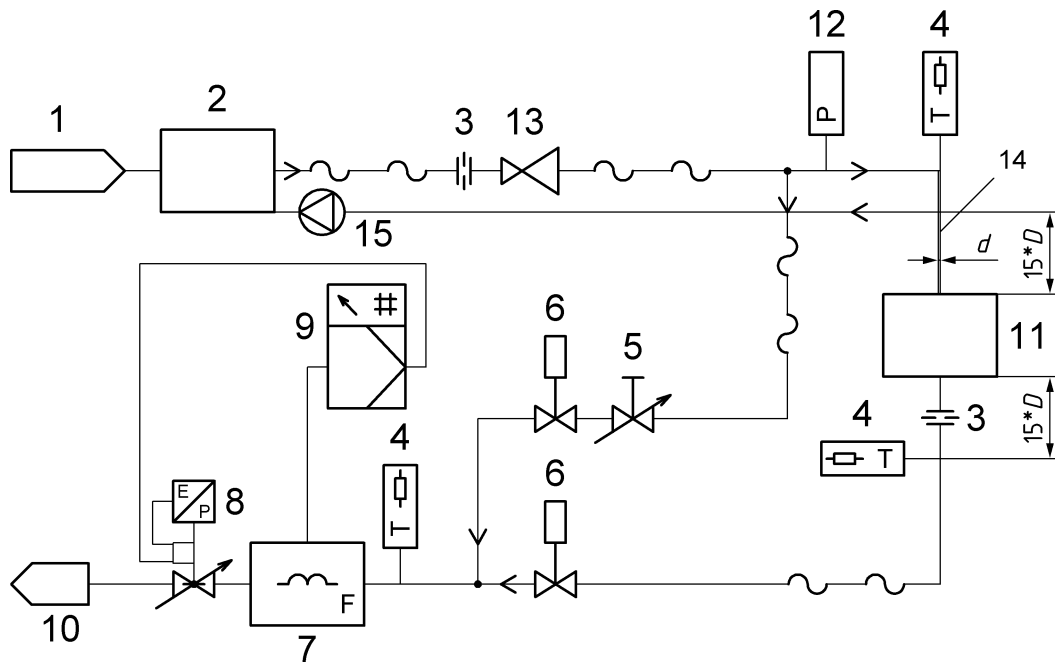

Key

- 1 water
- 2 preparator of water at 10 °C
- 3 diaphragm to homogenise the temperature and pressure profile across the tube diameter
- 4 temperature measurement device
- 5 equilibrium valve
- 6 electrovalve
- 7 flowmeter
- 8 control valve
- 9 rate control
- 10 drain
- 11 appliance in test
- 12 pressure measurement device
- 13 pressure control
- 14 cold water connection part consist of stainless steel
- 15 circulator of cold water circuit

Figure B.1 — Example of test rig

B.2 Pressure measurement

An example of the pressure measurement device is shown in Figure B.2. The lengths of the pipe upstream and downstream of the pressure measurement device are $15D$ and $5D$, where (D) is the diameter of the pipe.

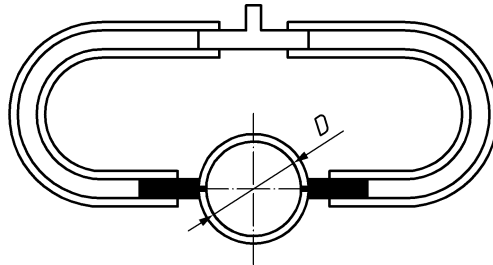

Figure B.2 — Example of pressure measurement device

B.3 Temperature measurement

Temperature sensors used in the test rig could be:

- thermocouples of type T, class 1, diameter of 0,5 mm;
- low inertia Pt 100 probe, diameter of 2 mm.

The temperature measurement device could be equipped with:

- 3 thermocouples + 1 Pt 100 probe, diameter 2 mm; or
- 4 thermocouples + 1 Pt 100 probe, diameter 2 mm.

An example of a temperature measurement device is shown in Figure B.3.

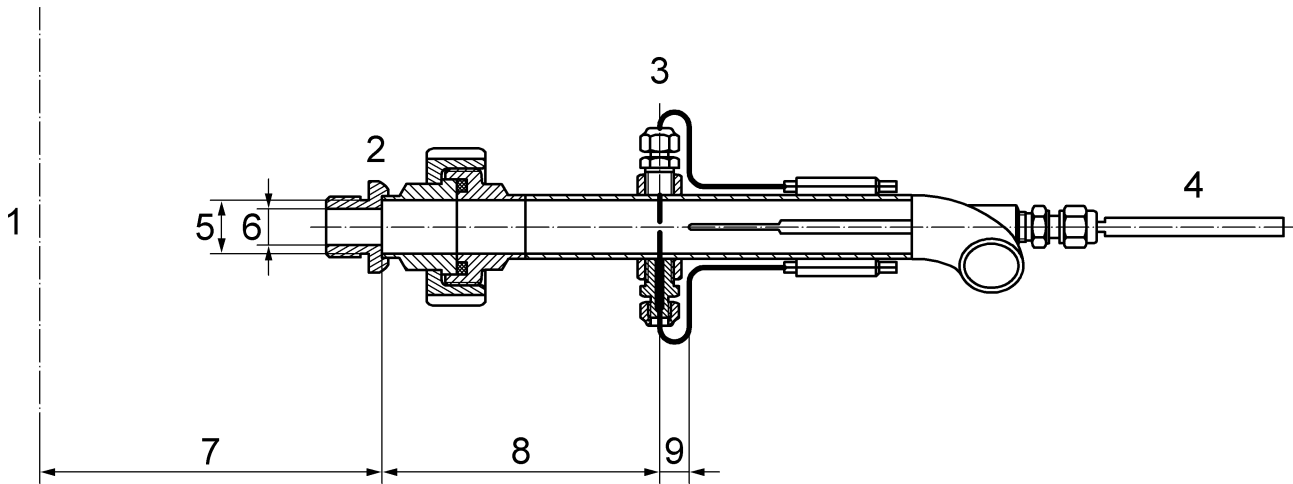

Key

- 1 outlet of the appliance in test (hole with $\varnothing D$)
- 2 diaphragm to homogenise the temperature and pressure profile across the tube diameter
- 3 thermocouple
- 4 platine probe
- 5 $\varnothing D$
- 6 $0,7 \times \varnothing D$
- 7 $< 10 \times \varnothing D$
- 8 $5 \times \varnothing D$
- 9 $> 0,5 D$ and $< D$

Figure B.3 — Example of temperature measurement device

The position of the thermocouples (three or four with one thermocouple at the centre of the flow) could be as shown in Figure B.4.

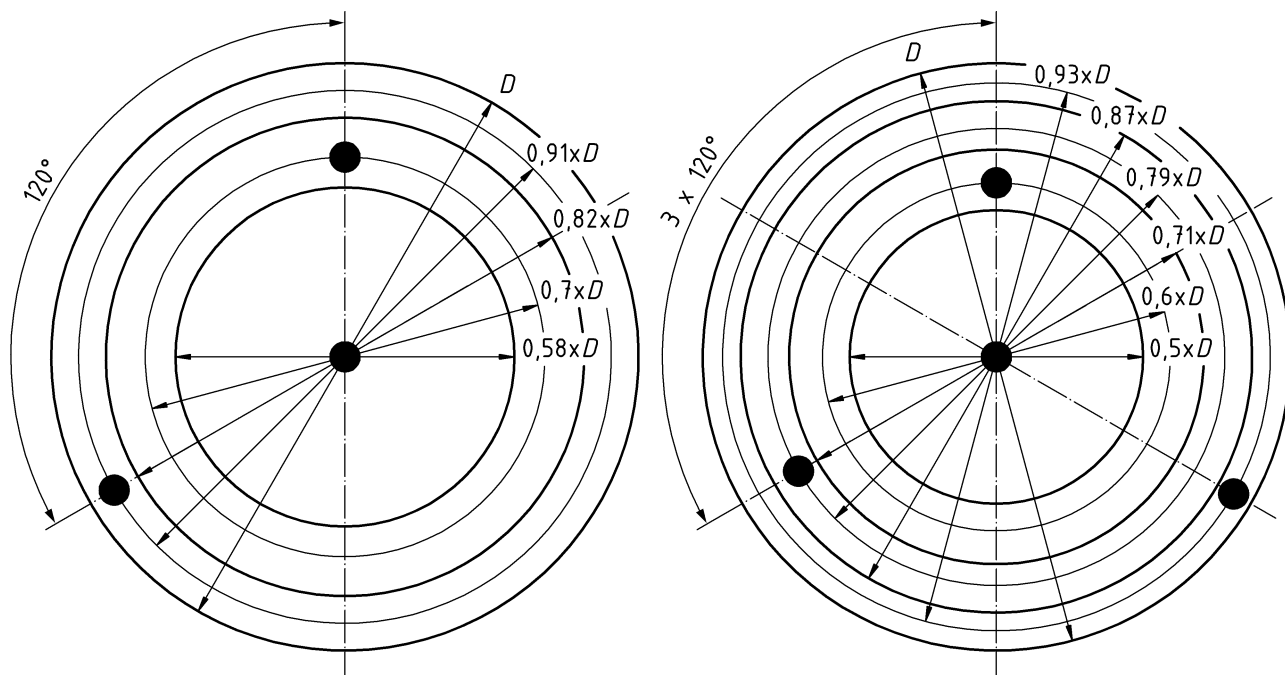

Key

- thermocouples

Figure B.4 — Example of position of thermocouples - Method of surfaces

Other measuring instruments may be used provided the results required in the standard are obtainable.

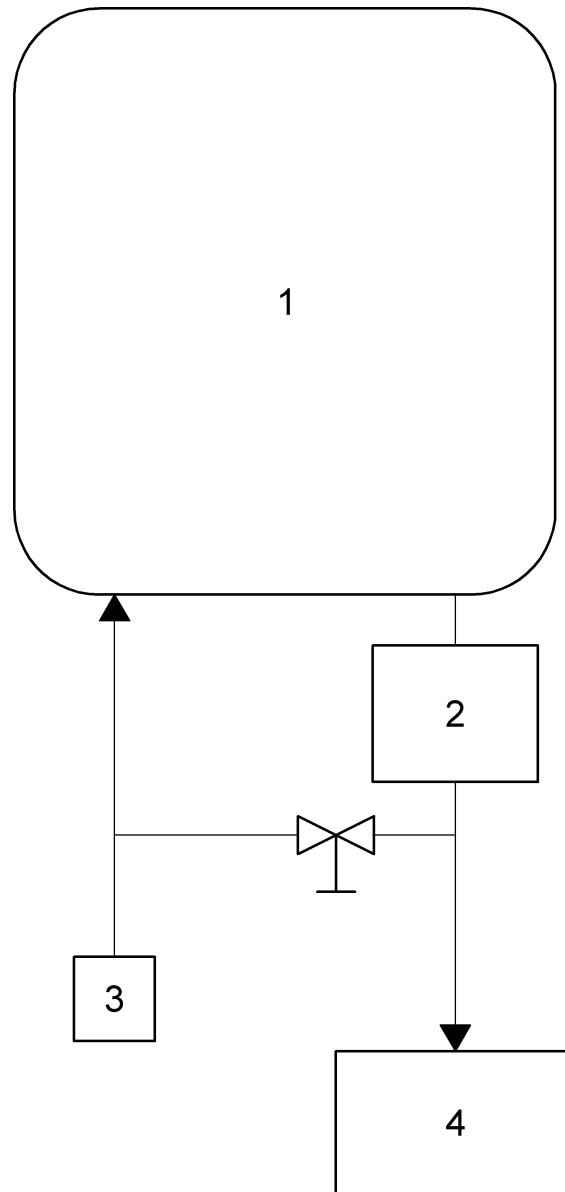
**Key**

1 gas appliance

2 $\frac{\Delta T_d}{D_{\min}}$ 3 T_d 4 $\frac{\Delta T_{\text{useful}}}{D_{\text{useful}}}$ **Figure B.5 — Useful and delivered flow rates and temperatures**

Annex C (informative)

Declaration of the Maximum Load Profile

In order to identify the maximum load profile the following Table C.1 may be used.

Table C.1 only takes into account nominal values. After having determined the maximum load profile, the one below the maximum load profile may be declared.

Table C.1 — Properties and Requirements for Load Profiles

Load profile	Reference energy Q_{ref} (kWh)	Equivalent water at 60°C (l)	Useful water flow rate (l/min)	Instantaneous water heaters Minimal thermal output (kW)	Storage water heaters Maximum volume (l)	Storage water heaters Minimum V40^a (l)
XS	2,1	36	3	6,3	15	
S	2,1	36	5	10,5	36	
M	5,85	100	6	12,6		65
L	11,66	200	10	20,9		130
XL	19,1	325	10	20,9		210
XXL	24,5	420	16	33,5		300
3XL	46,76	800	48	100,5		520
4XL	93,52	1600	96	200,9		1040

^a V40 is the quantity of water at 40 °C, which has the same heat content (enthalpy) as the hot water which is delivered above 40 °C at the output of the water heater, expressed in litres. See 7.4.

Annex ZA (informative)

Relationship between this European Standard and the ecodesign requirements of Commission Regulation (EU) n° 814/2013 [OJEU L239 of 6 September 2013] aimed to be covered

This European Standard has been prepared under a Commission's standardization request "M/534/C (2015) 2625 final" to provide one voluntary means of conforming to the ecodesign requirements of Commission Regulation (EU) No 814/2013 of 2 August 2013 implementing Directive 2009/125/EC of the European Parliament and of the Council with regard to ecodesign requirements for water heaters and hot water storage tanks [OJEU L285 of 31st October 2009].

Once this standard is cited in the Official Journal of the European Union under that Commission Regulation, compliance with the normative clauses of this standard given in Table ZA.1 confers, within the limits of the scope of this standard, a presumption of conformity with the corresponding eco-design requirements of that Regulation and associated EFTA regulations.

Table ZA.1 — Correspondence between this European Standard and Commission Regulation (EU) No 814/2013 of 2 August 2013 implementing Directive 2009/125/EC of the European Parliament and of the Council with regard to ecodesign requirements for water heaters and hot water storage tanks [OJEU L285 of 31 October 2009] and Commission's standardisation request M/534/C (2015) 2625 final

Ecodesign requirements of Regulation (EU) No 814/2013	Clause(s)/sub-clause(s) of this EN	Remarks/Notes
Annex II, 1.1 a), b), c) Requirements for water heating energy efficiency	7.1	
Annex II, 1.3 Requirements for mixed water at 40°C	7.4	This requirement applies only for storage water heaters according to EN 89

WARNING 1 — Presumption of conformity stays valid only as long as a reference to this European Standard is maintained in the list published in the Official Journal of the European Union. Users of this standard should consult frequently the latest list published in the Official Journal of the European Union.

WARNING 2 — Other Union legislation may be applicable to the products falling within the scope of this standard.

Annex ZB
(informative)

Relationship between this European Standard and the energy labelling requirements of Commission Delegated Regulation (EU) No 812/2013 [OJEU L239 of 6 September 2013] aimed to be covered

This European Standard has been prepared under a Commission's standardization request "M/534/C (2015) 2626 final" to provide one voluntary means of conforming to the energy labelling requirements of Commission Delegated Regulation (EU) No 812/2013 of 18 February 2013 supplementing Directive 2010/30/EU of the European Parliament and of the Council with regard to the energy labelling of water heaters, hot water storage tanks and packages of water heater and solar device [OJEU L153 of 18 June 2010].

Once this standard is cited in the Official Journal of the European Union under that Regulation, compliance with the normative clauses of this standard given in Table ZB.1 confers, within the limits of the scope of this standard, a presumption of conformity with the corresponding energy labelling requirements of that Regulation and associated EFTA regulations.

Table ZB.1 — Correspondence between this European Standard and Commission Delegated Regulation (EU) No 812/2013 of 18 February 2013 supplementing Directive 2010/30/EU of the European Parliament and of the Council with regard to the energy labelling of water heaters, hot water storage tanks and packages of water heater and solar device [OJEU L153 of 18 June 2010] and Commission's standardisation request "M/534/C (2015) 2626 final"

Energy labelling requirements of Regulation (EU) No 812/2013	Clause(s)/sub-clause(s) of this EN	Remarks/Notes
Annex III, point 1.1.1 or 1.1.2, and Annex VIII, 2 Annual Electricity Consumption (AEC)	7.2	
Annex III, point 1.1.1 or 1.1.2, and Annex VIII, 2 Annual Fuel Consumption (AFC)	7.3	

WARNING 1 — Presumption of conformity stays valid only as long as a reference to this European Standard is maintained in the list published in the Official Journal of the European Union. Users of this standard should consult frequently the latest list published in the Official Journal of the European Union.

WARNING 2 — Other Union legislation may be applicable to the products falling within the scope of this standard.

Annex ZC (informative)

Relationship between this European Standard and the ecodesign requirements of Commission Regulation (EU) n° 813/2013 [OJEU L239 of 6 September 2013] aimed to be covered

This European Standard has been prepared under a Commission's standardization request "M/535/C (2015) 2626 final" to provide one voluntary means of conforming to the ecodesign requirements of Commission Regulation (EU) No 813/2013 of 2 August 2013 implementing Directive 2009/125/EC of the European Parliament and of the Council with regard to ecodesign requirements for space heaters and combination heaters [OJEU L285 of 31st October 2009].

Once this standard is cited in the Official Journal of the European Union under that Commission Regulation, compliance with the normative clauses of this standard given in Table ZC.1 confers, within the limits of the scope of this standard, a presumption of conformity with the corresponding eco-design requirements of that Regulation and associated EFTA regulations.

Table ZC.1 — Correspondence between this European Standard and Commission Regulation (EU) No 813/2013 of 2 August 2013 implementing Directive 2009/125/EC of the European Parliament and of the Council with regard to ecodesign requirements for space heaters and combination heaters [OJEU L285 of 31 October 2009] and Commission's standardisation request M/535/C (2015) 2626 final

Ecodesign requirements of Regulation (EU) No 813/2013	Clause(s)/sub-clause(s) of this EN	Remarks/Notes
Annex II, 2(a), 2(b) Requirements for water heating energy efficiency	7.1	

WARNING 1 — Presumption of conformity stays valid only as long as a reference to this European Standard is maintained in the list published in the Official Journal of the European Union. Users of this standard should consult frequently the latest list published in the Official Journal of the European Union.

WARNING 2 — Other Union legislation may be applicable to the products falling within the scope of this standard.

Annex ZD
(informative)

Relationship between this European Standard and the energy labelling requirements of Commission Delegated Regulation (EU) No 811/2013 [OJEU L239 of 6 September 2013] aimed to be covered

This European Standard has been prepared under a Commission's standardization request "M/535/C (2015) 2625 final" to provide one voluntary means of conforming to the energy labelling requirements of Commission Delegated Regulation (EU) No 811/2013 of 18 February 2013 supplementing Directive 2010/30/EU of the European Parliament and of the Council with regard to energy labelling of space heaters, combination heaters, packages of space heater, temperature control and solar device and packages of combination heater, temperature control and solar device [OJEU L153 of 18 June 2010].

Once this standard is cited in the Official Journal of the European Union under that Regulation, compliance with the normative clauses of this standard given in Table ZD.1 confers, within the limits of the scope of this standard, a presumption of conformity with the corresponding energy labelling requirements of that Regulation and associated EFTA regulations.

Table ZD.1 — Correspondence between this European Standard and Commission Delegated Regulation (EU) No 811/2013 of 18 February 2013 supplementing Directive 2010/30/EU of the European Parliament and of the Council with regard to energy labelling of space heaters, combination heaters, packages of space heater, temperature control and solar device and packages of combination heater, temperature control and solar device [OJEU L153 of 18 June 2010] and Commission's standardisation request "M/535/C (2015) 2625 final"

Energy labelling requirements of Regulation (EU) No 811/2013	Clause(s)/sub-clause(s) of this EN	Remarks/Notes
Annex V, Table 7, and Annex VI, 2 Annual Electricity Consumption (AEC)	7.2	
Annex V, Table 7, and Annex VI, 2 Annual Fuel Consumption (AFC)	7.3	

WARNING 1 — Presumption of conformity stays valid only as long as a reference to this European Standard is maintained in the list published in the Official Journal of the European Union. Users of this standard should consult frequently the latest list published in the Official Journal of the European Union.

WARNING 2 — Other Union legislation may be applicable to the products falling within the scope of this standard.

Bibliography

- [1] EN 13203-1, *Gas fired domestic appliances producing hot water — Part 1: Assessment of performance of hot water deliveries*